

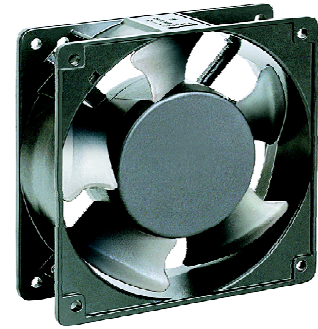

EC Axial Fans

- Motor Design : EC Technology
- Housing : **Aluminium** Die-cast
OR
: **Plastic** (PBT)
- Impellor : PBT (Polybutylene Terephthalate)
- Bearing : Sleeve or Ball Bearing
- Operating Voltage : 230V (185 - 245 VAC)
- Dielectric Strength : AC 500V for 1 minute
- Insulation : Class B
- Insulation Resistance : Above 10M Ohms at 500 VDC
- Connection : **Lead Wire**
- Motor Protection : Via Electronics
- Operating Temperature : - 10 to +70°C for Sleeve Bearing
- 20 to +70°C for Ball Bearing
- Net Weight : 310 Grams (Aluminium Housing)
245 Grams (Plastic Housing)

120 x 120 x 38 mm



Specification

Model No.	Code No.	Bearing	Voltage	Frequency	Current	Input Power	Speed ±5 %	Air Flow	Static Pressure	Noise	Box Packing
EC			V	Hz	A	W	RPM	CFM	mm H ₂ O	dB(A)	Nos.
EC - 12038 A2 W - 01	EC024	Sleeve	230	50/60	0.07	5.8	2700	105	7	43	40
EC - 12038 A2 W - 02	EC028	Sleeve	230	50/60	0.07	5.8	2700	105	7	43	
EC - 12038 B2 W - 02	EC032	Ball	230	50/60	0.07	5.8	2800	110	7.4	43	

Note : A = Sleeve Bearing B = Ball Bearing 2 = 230 Volt W = Lead Wire 01 = Plastic Body 02 = Aluminium Body

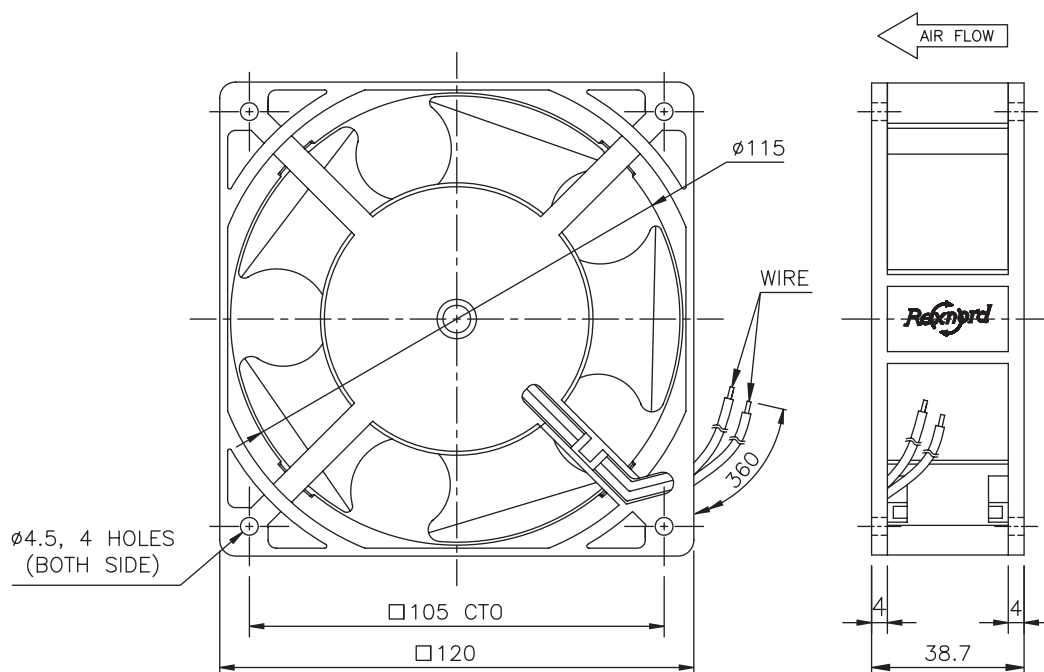

* Specifications Subject to Change Without Notice